



PRODUCT CODES: 56501, 56502, 56503 & 56504

Spark Detection and Extinguishing System

APPLICATIONS

The Raptor Spark™ Detection and Extinguishing System is an FM APPROVED safety device that is designed to detect and extinguish sparks and glowing embers that are traveling through a duct system. The hazard is detected by infrared sensors and extinguished with water spray nozzles within milliseconds of detection. The High Power Raptor Spark™ Detection control module has the capacity to receive hazard alert signals from multiple components (Dust Probes & Thermal Probes) and monitor multiple duct-zones and vessels.

The Raptor Spark™ Detection and Extinguishing System is an essential Fire Protection, Fire Isolation and Diversion device that is commonly installed with EcoMAXX® High Speed Abort Gates, FireBreak Shutters, EcoMAXX®/VigilEX Explosion Vents and explosion certified EcoMAXX®/VDL Rotary Valves. Typical automatic functions include hazard detection, system shut-down, isolation/abort, and extinguish and/or suppression.

CERTIFICATIONS & STANDARDS

Models P and MA

ATEX EN 1366-2, EN 13501

CSI 1643FR, REI 120-RE 120

CE



STANDARD FEATURES

- Output for Pre-Alarm
- 4-20mA proportional output
- IP65 Enclosure
- Output for Alarm
- Bus RS485

OPTIONAL FEATURES

- Magnetic
- Pneumatic
- Fusible Link



Raptor Spark™ Detection & Extinguishing Control Unit RS-PCUSP1L

The Raptor Spark Detection & Extinguishing Control Unit (RS-PCUSP1L) is designed to minimize the risk of fire and explosion in dust filtration and pneumatic conveying systems. This control unit communicates with a variety of components to monitor and protect up to six individual zones. The Control Units, RS-PCU1610SD & RS-PCUSP1L, are FM Approved.



Raptor Spark™ Extinguishing Assembly RS-EXT02

The Extinguishing Assembly (RS-EXT02) is designed to work in conjunction with the RS-PCUSP1L control unit and RS-SD02 Spark Detectors. When the control module gets a signal that a hazard has been detected, the extinguishing assembly is activated. A water spray is initiated inside the piping system to extinguish sparks or glowing embers that could cause fire or explosion. The Extinguishing Assembly (RS-EXT02) is FM Approved and ATEX Certified.



Raptor Spark™ Dust Probe RS-DP03

The Dust Probe (RS-DP03) is a charge displacement probe that uses the principle of the displacement of the electric charge in the electrode. It signals the RS-PCUSP1L Control Unit when there is an increase in the concentration of dust levels which could potentially indicate the rupture or ineffective operation of dust filters and/or dust bags. The Dust Probe (RS-DP03) is FM Approved and ATEX Certified.



Raptor Spark™ Thermal Probe RS-TP02

The Thermal Probe (RS-TP02) is designed to work either as a thermovelocimetric output (rapid raise in temperature in a short amount of time), or as a thermostatic output (fixed temperature threshold) to alarm the RS-PCUSP1L Control Unit of potential fire hazards in the ductwork, dust collector units, hoppers, cyclones and etc. The Thermal Probe (RS-TP02) is FM Approved and ATEX Certified.

Raptor Spark™ Spark Detector RS-SD02

The Spark Detector (RS-SD02) is designed to work with the RS-PCUSP1L Control Unit. The Spark Detector uses advanced technology and circuit, sensitive to infrared light to detect sparks, flames, and incandescent material that passes in front of its optical element. The Spark Detector (RS-SD02) is FM Approved and ATEX Certified.



Raptor Spark™ Test Lamp RS-TL02

The Test Lamp (RS-TL02) is designed to work in association with the Spark Detectors (RS-SD02). The Test Lamp provides a function check to ensure the cleanliness of the Spark Detector lenses by emitting high infrared radiation into ducting or pneumatic conveying lines across from the spark detectors to simulate a spark or glowing ember in the line. The Test Lamp (RS-TL02) is FM Approved and ATEX Certified.



EcoMAXX® Firebreak Shutter EM-FBS-00

The FireBreak Shutter is engineered to isolate fires and fire hazards in process ventilation and dust collection applications. The Fire Break Shutter can be activated by the EM-FCS-CU1610 Control Unit or RS-PCUSP1L via Spark Detection or sensing activation by Thermal Probe.



Water Pressure Booster Pump RS-CPR

The Raptor Spark™ Water Pressure Booster Pump RS-CPR was designed to regulate water pressure going into the extinguishing unit. It is the best solution for facilities that have over or under pressure water lines available for installation of the Spark Detection and Extinguishing System.





PRODUCT CODES: 56501, 56502, 56503 & 56504

APPLICATION AND GUIDELINES

Raptor Spark™
Dust Probe

Raptor Spark™
Thermal Probe

Ecomaxx®
FireBreak Shutter

Raptor Spark™
Alarm Bell

Raptor Spark™
Alarm Light

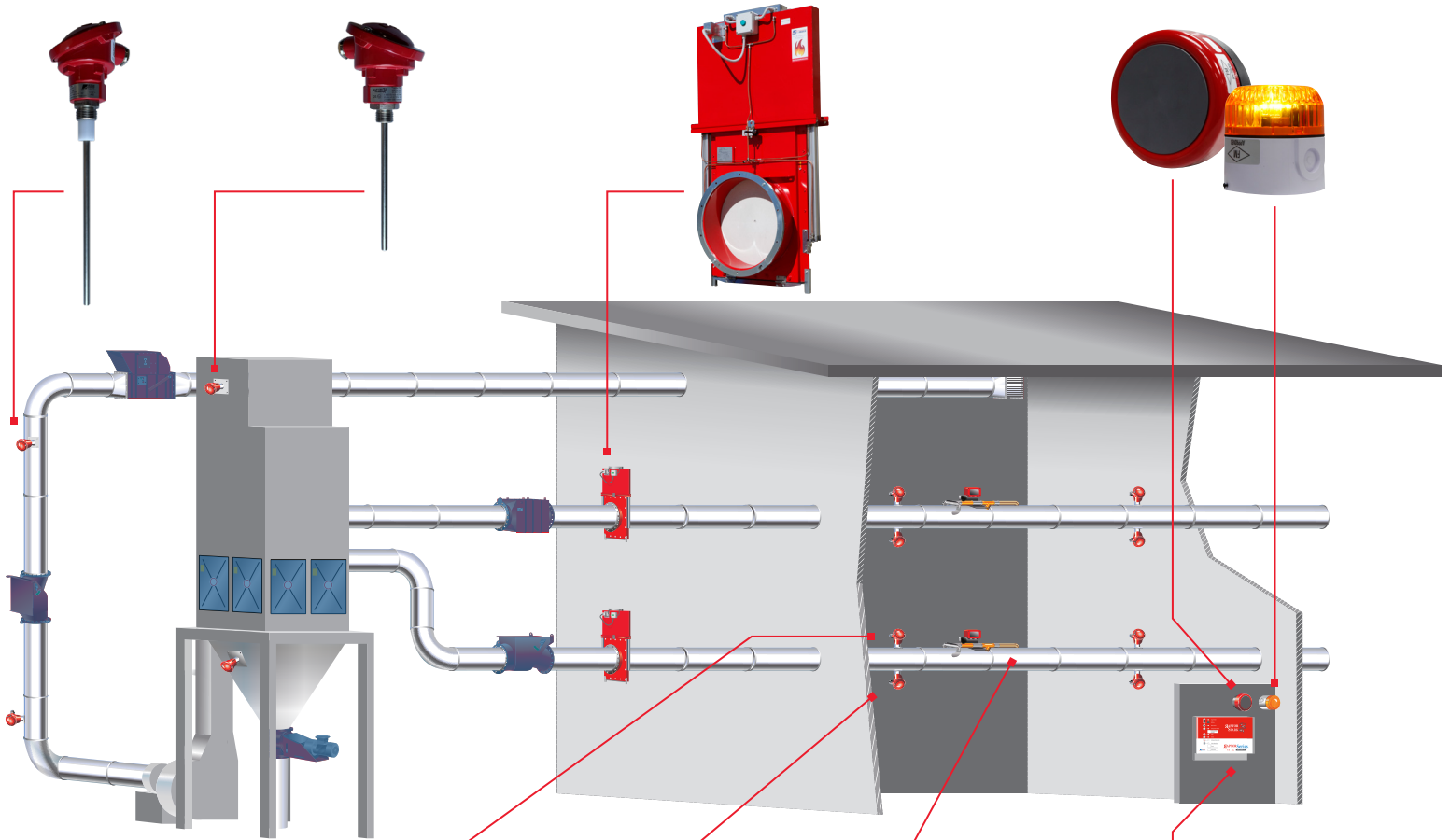

Raptor Spark™
*Spark Detector
(Infrared Sensor)*

Raptor Spark™
Test Lamp

Raptor Spark™
Extinguishing Assembly

Raptor Spark™
*Spark Detection and
Extinguishing Control Unit*

copyright 2022 Boss Products, LLC