

# High Speed Abort Gate EM-HSAG02

## APPLICATIONS

The **High Speed Abort Gate EM-HSAG02** is specifically designed to be installed as a safety component when filtered air is returned to a building. **NFPA** requires a **High Speed Abort Gate** to be activated by an **FM Approved Raptor Spark Detection and Extinguishing System**. When the **Raptor Spark™ Detection & Extinguishing Control Module** detects a potential hazard, the return air is diverted to atmosphere, aborting potential fire from entering a workspace. This abort function can also be activated by the **Dust Probe** when dust particles are detected and/or the **Thermal Probe**.

The **High Speed Abort Gate EM-HSAG02** is just one of the essential **Fire & Explosion Protection** system components provided by **Boss Products**. This component includes specific protection for **Explosion Prevention, Fire Isolation & Diversion**, specifically designed and engineered to be installed for the protection of workers, equipment, and buildings.



## CERTIFICATIONS & STANDARDS

*NFPA Compliant when used in conjunction with FM Approved Spark Detection System*



## STANDARD FEATURES

- 24V DC Control Panel with Status Lights
- Weather Hood
- Manual Reset Level
- Epoxy Powder coated safety red finish
- Flanged Inlet & Outlet
- NFPA Compliant with Spark Detection
- Electromagnetic Locking Mechanism

## OPTIONAL FEATURES

- 110V AC Control Panel with Status Lights Pneumatic Reset EcoMAXX® Spark Detection & Extinguishing System

## TECHNICAL INFORMATION

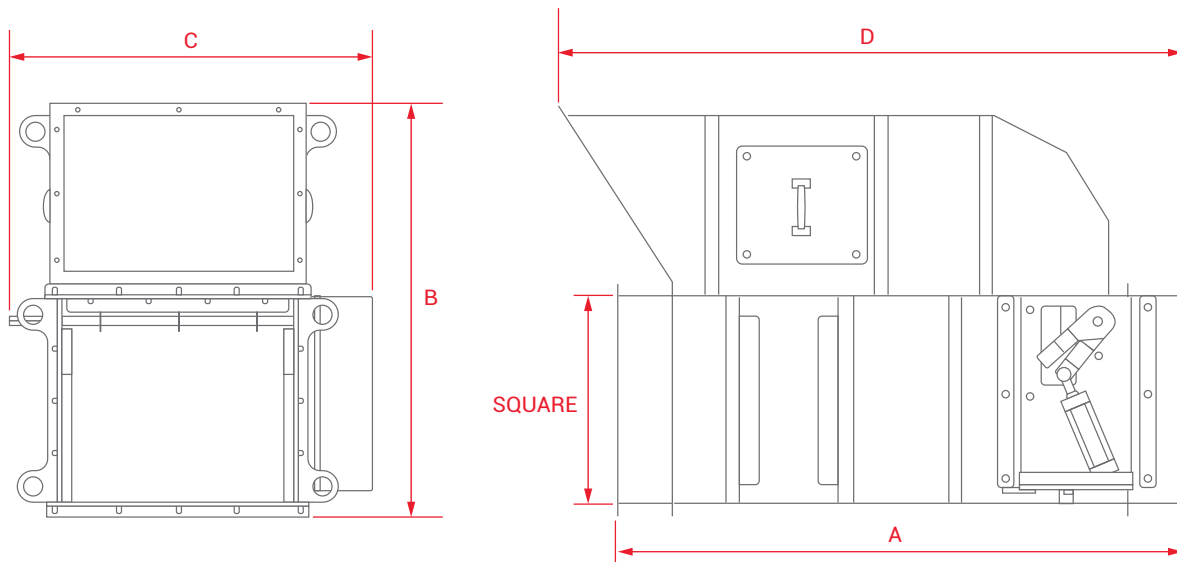

### HIGH SPEED ABORT GATE SPECIFICATIONS

Ø [in] equivalent	Square [in]	Voltage	Reset	A [in]	B [in]	C [in]	D [in]
20	18x18	24 VDC	Manual Lever	41.0	25	12	40.50
24	22x22	24 VDC	Manual Lever	55.0	44	22	59.19
36	32x32	24 VDC	Manual Lever	77.5	63	32	87.44
44	40x40	24 VDC	Manual Lever	97.5	78	40	111.50
54	48x48	24 VDC	Manual Lever	115.5	92	48	132.94
60	54x54	24 VDC	Manual Lever	115.5	104	54	136.44
68	60x60	24 VDC	Manual Lever	115.5	115	60	136.44

copyright 2021 Boss Products, LLC