

Certified Rotary Valve EMVDL-RVEX-MD

APPLICATIONS

- Passive explosion isolation requiring rotor access for frequent cleaning
- Differential pressures **up to 400" WG**
- Heavy Duty design, ideal for high vacuum applications
- Recommended for pneumatic conveying of process material and dust feeder valve for screw conveyors, scales, classifiers dryers and coolers

CERTIFICATIONS & STANDARDS

EN 15089

CE 0588 ⚡ II ID/* c T4 ⚡ D FSA 15 ATEX 1661/1662 X

NFPA 69 compliant

Flex tip design certified to prevent flame passage

NFPA 69 12.2.4.3.6 compliant

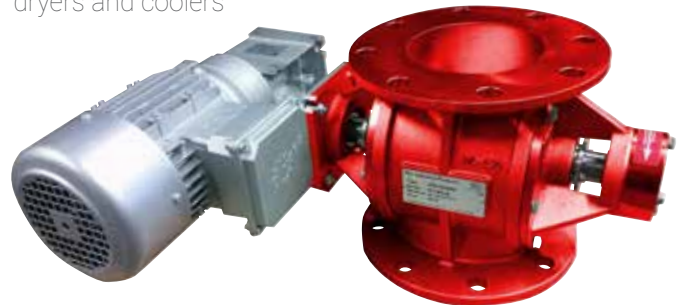

STANDARD FEATURES

- Explosion & Flame Proof design to **36 psi / 2.5 bar** (**25 psi / 1.7 bar** with polyurethane flex tip rotor)
- Cast iron housing with round inlet and outlet
- Direct Drive **15 RPM, IP65 gearmotor** w/flex coupling
- Removable 8 vane polyurethane, steel or S/S rotor
- Adjustable Gland Pack bearings for shaft sealing
- High fill ratio with very low leakage & product damage

OPTIONAL FEATURES

- Motors for hazardous locations and extreme temperature
- **30 RPM** gearmotor with EM variable speed control package
- Special construction, stainless steel, chromium/nickel plating
- Insulation box, speed monitors, flange gasket, injector fittings and product scrapers

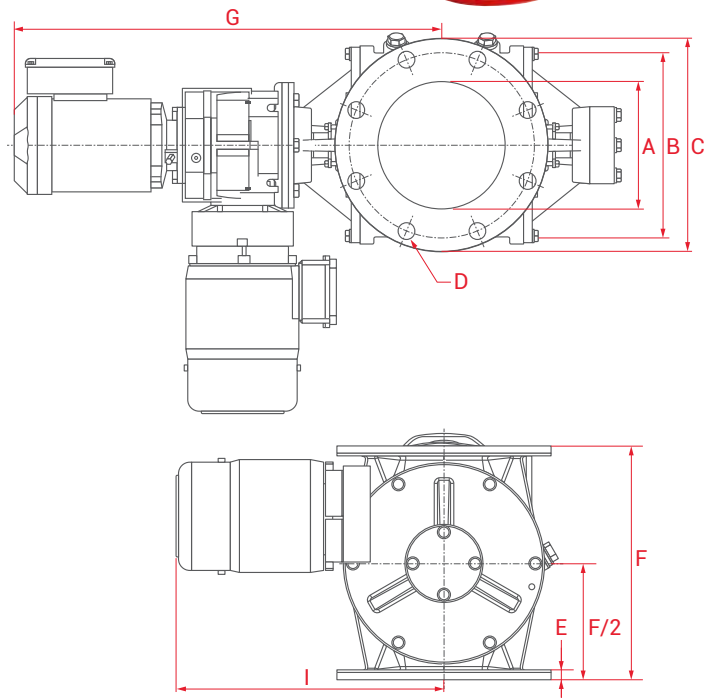

DIMENSIONS *

MODEL	15 RPM HP	30 RPM HP	CAPACITY FT ³ (LTR)	Ø A	Ø B	Ø C	D	E	F	G	H	I
EMVDL RVEX-MD150	0.50	0.75	0.10 (3)/rev	6" (150 mm)	9" (240 mm)	11" (285 mm)	8 x Ø23 mm	0.51" (13 mm)	10" (260 mm)		13" (330 mm)	14" (355 mm)
EMVDL RVEX-MD200	0.75	1.50	0.39 (11)/rev	8" (200 mm)	12" (300 mm)	13" (340 mm)	8 x Ø23 mm	0.51" (13 mm)	15" (370 mm)		16" (400 mm)	21" (525 mm)
EMVDL RVEX-MD250	1.00	1.00	0.74 (21)/rev	10" (250 mm)	14" (350 mm)	16" (395 mm)	12 x Ø23 mm	0.67" (17 mm)	17" (425 mm)	30" (770 mm)		
EMVDL RVEX-MD300	1.50	3.00	1.30 (37)/rev	12" (300 mm)	16" (400 mm)	18" (445 mm)	12 x Ø23 mm	0.79" (20 mm)	20" (500 mm)	33" (840 mm)		

Columns G, H and I depend on drive

* Units in inches rounded to the closest whole number