

Certified Rotary Valve EMVDL-RVEX-BS

APPLICATIONS

- Passive explosion and flame isolation
- Differential pressures up to 28" WG
- Ideal for wood applications w/flex-tip rotor
- Rotary airlock for dust collectors and cyclones

CERTIFICATIONS & STANDARDS

ATEX 1D/2D T4 safety system

CE 0588 II 1D/2D T4 (Device Inside/Outside) D
(Protective system) FSA 15 ATEX 1658 X

NFPA 69 compliant

Flex tip design certified to prevent flame passage

NFPA 69 12.2.4.3.6 compliant



STANDARD FEATURES

- Explosion and flame isolation up to 7 psi / 0.5 bar
- 8 vane flex-tip NFPA 69 compliant rotor, Ex/flame proof
- 15 RPM, IP65 direct drive gear motor with flex coupling
- Inlet/ discharge size 20" X 20," 20" X 30" & 20" X 40"
- Requires system integrated control panel for ATEX certification

OPTIONAL FEATURES

- Motors for hazardous locations and extreme temperature
- 30 RPM gear motor with EM variable speed control package
- EM system integration package required for ATEX certification
- Stainless steel construction, Insulation box, speed monitor, flange gasket

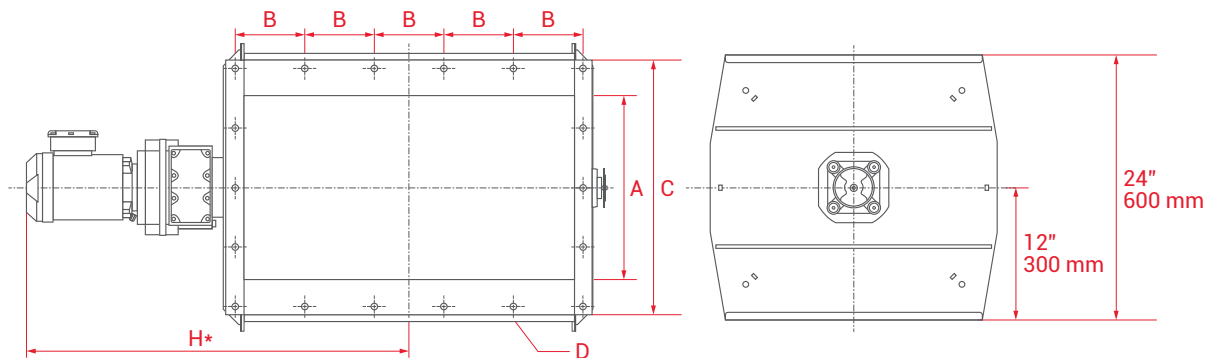

DIMENSIONS *

MODEL	15 RPM HP	30 RPM HP	CAPACITY FT ³ (LTR)	A	B	C	D	H
EMVDL RVEX-BS500	1.00	2.00	4.41 (125)/rev	20" x 20" (500 x 500 mm)	0.16" x 5.30" (4 x 135 mm)	23" x 23" (580 x 580 mm)	16 x Ø 10.5 mm	30" (742 mm)
EMVDL RVEX-BS750	1.00	2.00	6.64 (188)/rev	20" x 30" (500 x 750 mm)	0.20" x 6.22" (5 x 158 mm)	23" x 33" (580 x 830 mm)	18 x Ø 10.5 mm	34" (867 mm)
EMVDL RVEX-BS1000	1.50	3.00	8.83 (250)/rev	20" x 40" (500 x 1000 mm)	0.31" x 5.12" (8 x 130 mm)	23" x 43" (580 x 1080 mm)	24 x Ø 10.5 mm	40" (997 mm)

Available as EMVDL-RVEX-BS, Rotary valve with explosion detector and control – Available as EMVDL-RV-BS, Rotary valve only
* Length varies dependent on motor selection – Units in inches rounded to the closest whole number